

Italian
Technology,
Manufactured
in India

 **KHIMSARIA**
ASSOCIATES

www.khimsaria.com

STR-300

**BUNDLING
MACHINE**

STRETCH BANDING

COMPACT | EFFICIENT | FLEXIBLE

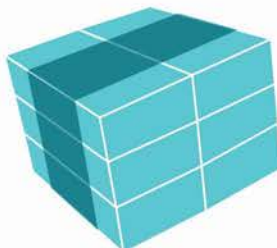
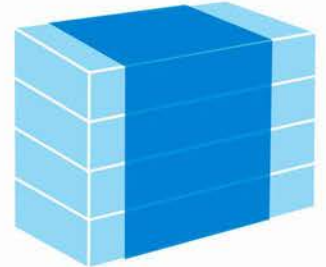
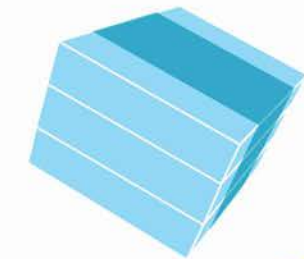
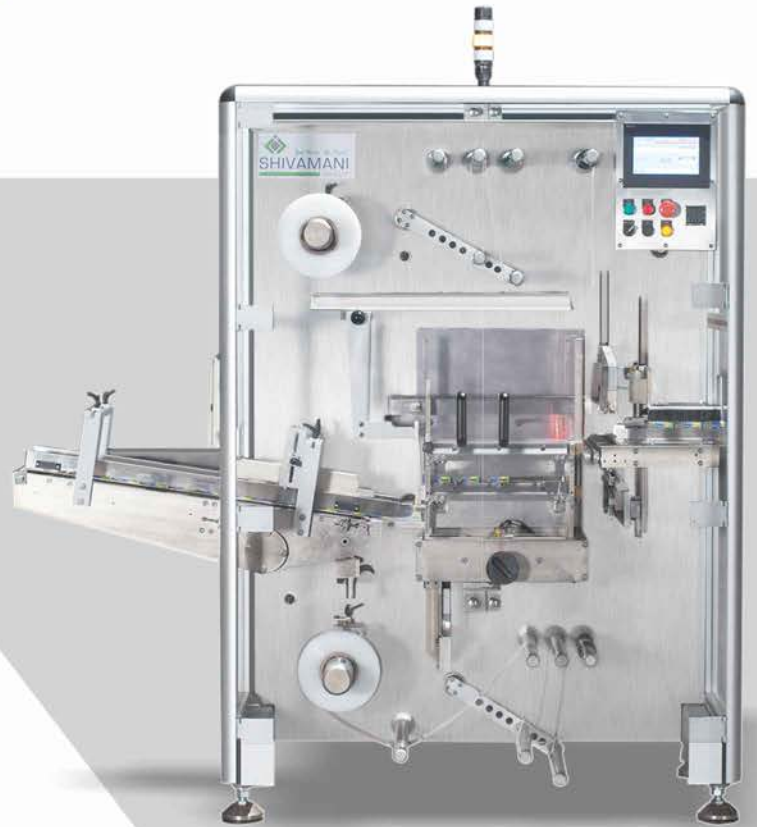

FEATURES:

- Balcony design with compact footprint.
- Servo Driven Pusher & Sealing System for flexibility and ease of settings.
- Unique system to ensure tightness of the band.
- Compact footprint to accommodate easily in the existing Line.
- Quick and easy change over.
- Auto Collation unit to create required Matrix.
- PLC with touch screen HMI.
- Speed up to 30 Bundles per min.

TWIN ROLL SYSTEM

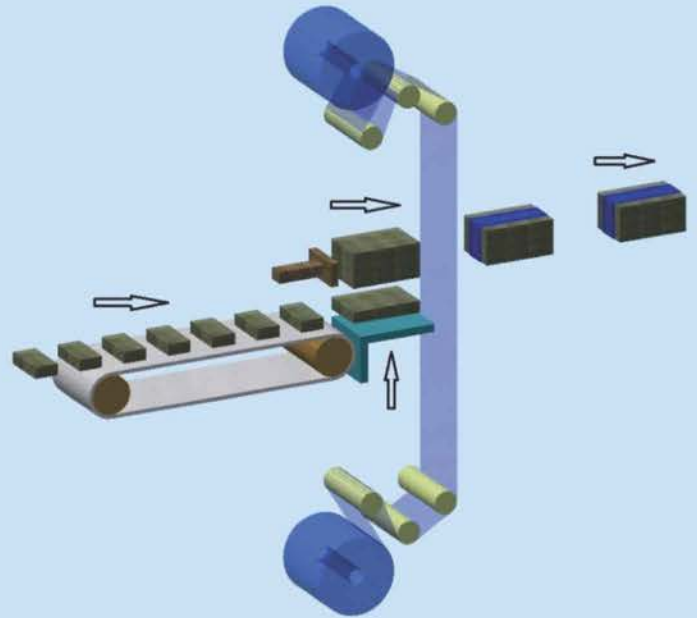

MACHINE LAYOUT

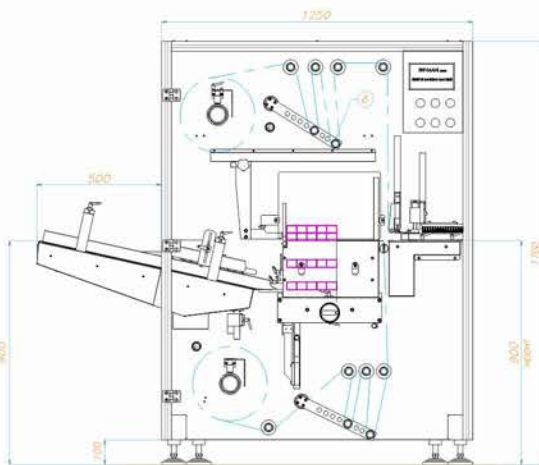

(ELEVATION)

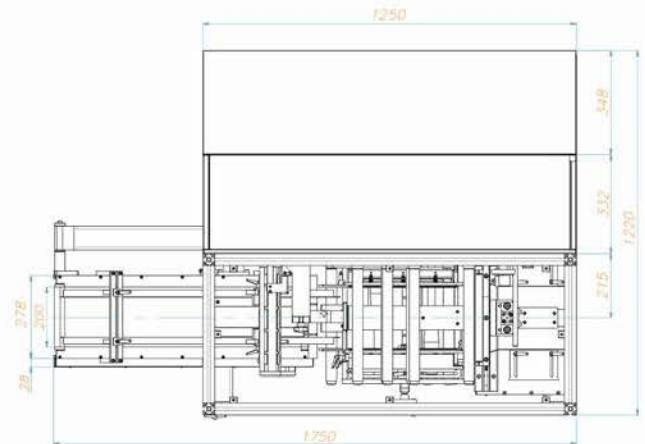

(FLOOR PLAN LAYOUT)

SIZE RANGE

PARAMETER	A	B	C	D	E	F	H
Min Value (mm)	20	12	60	60	30	60	40
Max Value (mm)	210	90	200	210	210	200	250

Customized versions available for higher size range

